



Proceedings of the 5th International

Symposium on Electronics in the Air Transport Industry

第五屆國際空運業電子學術會議

SEATI 2006



Hong Kong Convention and Exhibition Centre
8-10 March 2006



**Organised by
The IEE Hong Kong**

This final version starts in the proceedings on page 134

Status and capabilities of advanced computer based analysis and simulations for ATC-navigation and radar systems - Examples and Results

Gerhard GREVING

NAVCOM Consult
Ziegelstr. 43
D-71672 Marbach / Germany
navcom.consult@t-online.de
<http://www.navcom.de>
Tel.: +49 7144 862560
Fax: +49 7144 862561



Invited Paper - Overview Paper

Abstract

The modern air-traffic is controlled and enabled today by electronic and radio systems even under all weather conditions. These systems (navaids, landing and radar systems) operate by the radio transmission of coded signals which are subject to distortions by “reflections”, so-called unwanted multipath signals. The effects of building and objects of various kinds or also of aircraft have to be determined in advance in case of new or extended airports. E.g. the introduction of the new A380 requires adapted airport layouts, large hangars and a large terminal infrastructure which may cause distortions for the existing or new systems. It would be very risky to build the objects and to wait to see what happens.

This overview paper describes a technique for system simulations and explains the steps in the simulation process. A so-called integrated hybrid system simulation (IHSS) scheme is explained which comprises the most modern numerical methods for the analysis of the scattering effects of the objects. The final result is always the decisive system parameter of the system in question, e.g. “DDM” for ILS (Instrument Landing System).

The IHSS scheme is demonstrated by two examples of the simulation process, namely the ILS-DDM-effects of an A380 while rolling off and the effects of a large TV-tower on the potential false interrogations of a MSSR-radar.

General Introduction

A typical situation today is that airports are extended by new runways or other infrastructure or even completely newly built. Another actual situation is that new buildings of increasingly large dimensions are constructed on existing airports or in the vicinity of existing ATC-systems. Also the aircraft on the airports are increasingly larger, e.g. the forthcoming A380, coping with the increasing air-traffic. All these challenges are threats for the electronic systems which support and enable the modern aviation, i.e. air-traffic during all weather conditions, including the so-called CATIII-operation.

Many different types of classical and modern systems which are related to air-traffic, are installed today on and around every major airport (Fig. 1) and enroute:

- Navigation systems
- Landing systems
- Radar systems
- Communication systems.

These systems are operating with radio transmission and reception. The frequency range extends roughly from 300kHz to 15GHz.

These systems on airports (Fig. 1) or enroute are working pretty well in the absence of scattering objects (scattering = reflections + diffraction). These objects can be buildings in a general sense or aircraft or temporary construction means such as scaffolding or tower cranes. The

enroute systems may be threatened by windgenerators ("windturbines") (Fig. 8) or high voltage lines or radio transmitters and TV-stations (Fig. 3). This type of TV-transmitter stations is planned currently around Hong Kong for the digital TV. The actual technical problem is if these TV-stations which are located on exposed high points of mountains may distort the ATC-infrastructure of Hong Kong in an in-acceptable way.

System Parameter

Each system has a certain task in the ATC-concept. This task is realized for the ATC-systems by radio transmission. The radiated signals are evaluated and processed in the receiver onboard or on the ground depending on the system. One main and most important parameter characterizes each system, the so-called "system parameter" which is processed subsequently by the pilot or the autopilot in the aircraft or by the controllers in case of the ATC-radar.

Typical system parameters are

- DDM for the ILS
- Bearing angle for the VOR/DVOR, TACAN, NDB
- Range for the DME
- etc.

For the ATC-radar systems this issue is somewhat more complicated. E.g., the secondary radar SSR/MSSR is based on the specified interrogation of the airborne transponder if the interrogation amplitude is above the MTL ("minimum threshold level"; effectively typically -71dBm for Mode S, -68dBm for Mode A/C outside the aircraft). The correct interrogation combined with the correct azimuth angle are the system parameter essentials. Both parameters can be distorted by scattering by objects. Another aspect is the potential shadowing which may reduce the range coverage of the SSR.

System Simulations

Depending on its characteristics, the mentioned major objects, such as large aircraft (Fig. 5), hangars (Fig.6), terminals and aircraft (Fig. 1, Fig. 2-8), can distort these systems in an unspecified way. The forth-

coming aircraft Airbus A380 (Fig. 4) is by far the largest civilian aircraft for regular air traffic. By its large conducting metallic body it has the capability of generating equivalently large scattering signals, which is an important actual issue for the standard landing system, namely the ILS. The ILS was invented in the 1930's of the last century and was continuously completed and upgraded in the course of the following decades. The ILS consists in its standard high performance configuration of 3 subsystems, namely the Localizer, the glidepath and the markers which may be substituted by the DME.

This ILS system parameter DDM is affected by the reflections and scattering caused by the mentioned objects. By that, every major relevant building activity or the forthcoming appearance of the new large aircraft A380 (Fig. 4) in a quite a number of various scenarios on the airports (Fig. 5) have to be analyzed in advance due to its effects on the systems by advanced systematic "system simulations". Because the effects are caused by "reflections" or "scattering" the analysis of the scattering properties of these objects is an integral part of the system simulations (Fig. 2).

Typical tasks of system simulations

- Installation and positioning of systems (e.g. position of radar tower, position and antenna geometry of ILS glide-path; determinations of the pedestal under ILS-Localizer)
- Definition of the layout of runways and taxiways on airports in case of new aircraft (e.g. A380)
- Analysis of the acceptance of new objects on airports or enroute (e.g. building applications of hangars, terminals, windturbines, cranes in case of construction)

A system simulation consists of 3 major blocks or steps

- System pre-analysis/processing, setup
- Modeling of the object and the antennas; scattering analysis
- System post-processing yielding the system parameter. Resulting proposals and conclusions

The more advanced the numerical methods are and the more realistic the evaluated models are, the more reliable and accurate are the results. It should be kept in mind that a model of the reality is solved and evaluated. However, often a “worst treatment” is a valuable approach as a first step. The idea and the arguments for this approach are that the object is acceptable when the worst-case model is acceptable. This approach has two critical problems

- the judgment if it is really the worst case
- the consequences from the worst case model can yield unacceptable restrictions and can create costly measures on the airports or in the coverage volume.

The system results have to be compared with the applicable specifications, e.g. the ICAO Annex 10 Vol. I and IV.

The ICAO-specifications are defined for a certain accepted balanced safety level. 100% safety or 0% risk is impossible. So, the final criterion for the acceptability of a building etc. is the sufficient compliance with the ICAO-specifications. The capabilities of the ATC-systems in terms of radiation characteristics or signal processing are steadily enhanced coping partially with the “threats”, the increasing air-traffic paired with the more difficult environment.

The mentioned numerical computer simulations are very useful also for the definition of the layout of airports, such as the layout of the taxiways for the intended operational category (up to CATIII) and the intended maximum aircraft. The interesting parameters are e.g.

- Shape and dimensions of the critical and sensitive areas
- Distances of parallel taxiways
- Position of the holding points.

The Fig. 5 depicts this issue for the case of the A380. From these systematic simulations the operationally important safeguarding areas and the holding points can be derived. It should be noted that these operationally important figures depend very much on the local boundary conditions, such as the existing basic error noise floor by the permanent buildings

created on the installed system-components. A humped runway requires much different safeguarding areas than the flat one or monotonically increasing one. The safeguarding areas can be in fact much larger. The type and quality of the used systems (e.g. for ILS single/dual frequency) and antennas (e.g. medium/wide aperture) have also very much impact on the results.

Modeling, Numerical Methods

Numerical scattering analysis methods have to be used which are embedded into the simulation process (Fig. 2). Many different kind of objects appear on the airports (Fig. 1), such as terminals, control towers, hangars, tanks, tower cranes, aircraft and vehicles, requiring different kind of suitable numerical methods. Fig. 2 shows the detailed general flow chart or the block diagram of such a highly sophisticated system simulation process, i.e. the IHSS "Integrated Hybrid System Simulations". This flow chart is applicable to every ATC system and every object in principle. The basic idea is to use the best available sophisticated numerical method in a hybrid superposition manner. The selection of the numerical method depends on the electrical size related to the wave-length and its constructional structure, such as

- plane or curved surfaces.
- Wire type structures like tower cranes or sliding doors.
- Materials used.

The different methods have different basic properties and features

- Rigorous and/or almost quasi-rigorous
- Approximate and asymptotic
- Ray-tracing, current integration
- Antenna and scattering analysis
- Wave propagation analysis in case of non-flat terrain, such as “humped runways” or mountainous terrain.

Several basic tasks have to be executed at the end of the main central block (Figure 2):

- Decision which of the available numerical methods have to be applied for the actual situation
- Modeling of the 3D-object (i.e. A380 etc.). The modeling has to take into the geometrical and the electrical aspects.
- Scattering analysis itself.

Generally speaking as a “state-of-the-art”-simulation procedure, the best available and applicable numerical methods should be used. It is not a state-of-the-art-procedure to use generally too approximative and over-simple numerical methods which are readily available and which are fast running. Speed may be desirable, but should not be an issue in the selection process of the numerical methods. The advanced numerical methods, such as

- GTD/UTD (Geometrical/uniform theory of diffraction)
- PTD/IPO (improved physical optics)
- MoM, ML-FMM (Method of moments, derivatives)
- PE (parabolic equation)

have been developed in electromagnetics outside the ATC systems community and have been verified in the electromagnetics field for vast number of cases. By that a basic safety is given to achieve reliable results when all the limitations and rules of applications are met. However, it must be also clear that the 3D-reality must be modeled by sufficiently accurate 3D-models (e.g. of the A380 in Fig. 4) used in the system simulation process. This proposed procedure guarantees inherently the most accurate results.

Verification, Validation, Accuracy

The analysis and the computer simulations have to be performed “in advance”, i.e. before the threatening objects are built. As a thumb of rule, other means of the advanced treatment are not feasible or are highly questionable for the system applications, such as a comparison with apparently “similar cases” or scaled modelling and scaled measurements. The reason is simply, that the cases are never really fully comparable or that the required system parameter cannot be scaled in frequency practically and, by that, the system pa-

rameter cannot be measured. Partial measurements of certain quantities which do not result in the system parameters or which are not directly related to the system parameter are more or less useless. It should be remembered that so-called “field distortions” are in most cases not directly related to the system parameters. A rare exception is the range effects by shadowing. Often, in the region of maximum field distortions the system parameter is zero or minimum, such as the angle error in the case of VOR/DVOR or of monopulse SSR directly behind the object.

The verification and the question of accuracy are legitimate issues and questions. The background of the questions is to expect or define the accuracy of the computer simulations in the order of some percent maximum. This is unrealistic despite the large number of affecting parameters. The other difficulty is the reference which result is supposed to be “correct” or shall be the “truth”. Often system measurements by ground or flight check are treated as the “correct reference”. However it is more than evident, that the measurements also have their own difficulties and do have their own errors as well as the simulations. The accuracy depends primarily on the model of the real object (2D vs 3D, approximations), second on the numerical methods for the scattering process, but to a large extent also on the system evaluation itself. The latter comprises the receiver model, signal processing issues (filtering, sampling) and the sensor model (receiving antenna, sensor platform).

The real problems in all the numerical simulations are unexpected and undiscovered errors in cases which are challenging the applied numerical methods, such as resonances or artifacts resulting from limitations in the methods. These types of errors may be minimized by extensive experience in the numerics and the theories. However, the most powerful “tools” for avoiding undiscovered errors are the permanent scepticism, a deep system experience and continuous plausibility checks and cross checks – or at the end by reliable and controlled measurements.

Examples and Results

Some examples shall demonstrate the issue and the modern capabilities of practical system simulations. They will be outlined in more detail during the symposium itself.

The results of the following 2 cases will be presented from methodological aspects as well as from the operational aspect

1. **ILS and A380;** Results around the A380 aircraft (Fig. 4) which include the airport layout as well as the associated maintenance hangar (Fig. 6). It will be outlined which parameters affect the results, such as the sensor antenna, the receiver issue and the signal processing issues (filtering, sampling). Fig. 9 shows an example result where the A380 departs from centreline on a fast roll-off taxiway. The roll-off point is in a distance of about 700m to the wide-aperture dual frequency localizer antenna. The presented DDM is simulated on a flight path of a landing aircraft when passing at ILS point A (outer marker). The maximum DDM-distortion is about $22\mu\text{A}$ in this modelled case. It can be clearly seen that the ICAO specifications are violated for CATII/III when the next landing aircraft is in typical distances of about 2NM to the threshold when the first landing is leaving the runway. On the other hand, if the roll-off point is closer to the localizer antenna, the distortions are larger and will exceed the general specification limit of $30\mu\text{A}$ up to the coverage limit.
2. **MSSR and TV-station in Hong Kong;** The reflections and scattering of an MSSR-radar from a radio and TV-tower are shown in Fig. 10. The interrogation signals caused by the scattering are unwanted and should be under the specified MTL in this particular case. The amplitude levels are colour coded and calculated on a 2D horizontal plane in a height of 3000ft, which is the lowest MRVA level in Hong Kong except in the vicinity of the airport. The 3D-model is shown as an insert, but is shown also in Fig. 3 (right). The base building consists of non-metallic structured concrete which exhibits an inherent reduction of the

reflections by $>6\text{dB}$ for the SSR-frequency. In total as a conclusion, the distortions by this TV-tower are acceptable for the MSSR yielding no false interrogations if the local MRVA-heights are applied.

Conclusions

Adequate system simulations according to state-of-the-art principles allow today the reliable evaluation of the effects of objects on navigation -, landing - and radar systems. A general procedure for such system simulations has been presented. It uses the most modern numerical methods for the scattering analysis, which are embedded in the system shell. Details have been explained and the problem of the verification and accuracy of the system results have been discussed. Two examples are presented in this paper: First, ILS-DDM-results for the effects of a rolling-off A380 for the next landing aircraft and, second, results for an MSSR-radar by simulating the effects of a TV-tower due to the potential false interrogations.

References

- /1/ Y.T. LO, S.W. LEE Antenna Handbook, Chapman&Hall, Vol. I, NewYork 1993
- /2/ G.GREIVING Advanced Numerical System Simulations for Nav aids and Surveillance Radar - The Verification Problem, 13th IFIS, June 2004, Montreal/Canada, pp.173-186
- /3/ G.GREIVING Modern threats to precision approach and landing - The A380 and windgenerators and its adequate numerical analysis, ISPA 2004; October 2004, Munich
- /4/ G. GREIVING Modern Numerical Analysis and Simulations for System Applications - Capabilities and Limitations Exemplified for the A380 Aircraft, ANTEM 2005, St.Malo/Rennes/France, June 2005
- /5/ G. GREIVING Analysis of the effects of objects in the radiation field of surveillance radars - Examples, Interpretation and Consequences, International Radar Symposium IRS 2003, DGON, Dresden October 2003, pp. 515-524
- /6/ G. GREIVING Analysis of the scattering fields for ATC radar by objects - Consequences of the application of different methods, International Radar Symposium IRS 2005, DGON, Berlin September 2005, pp. 439-448
- /7/ G. GREIVING System Simulations for Navigation and Radar Applications Based on Sophisticated Numerical Hybrid Scattering Analysis, MAPE 2005, Beijing/China, August 8-12, 2005

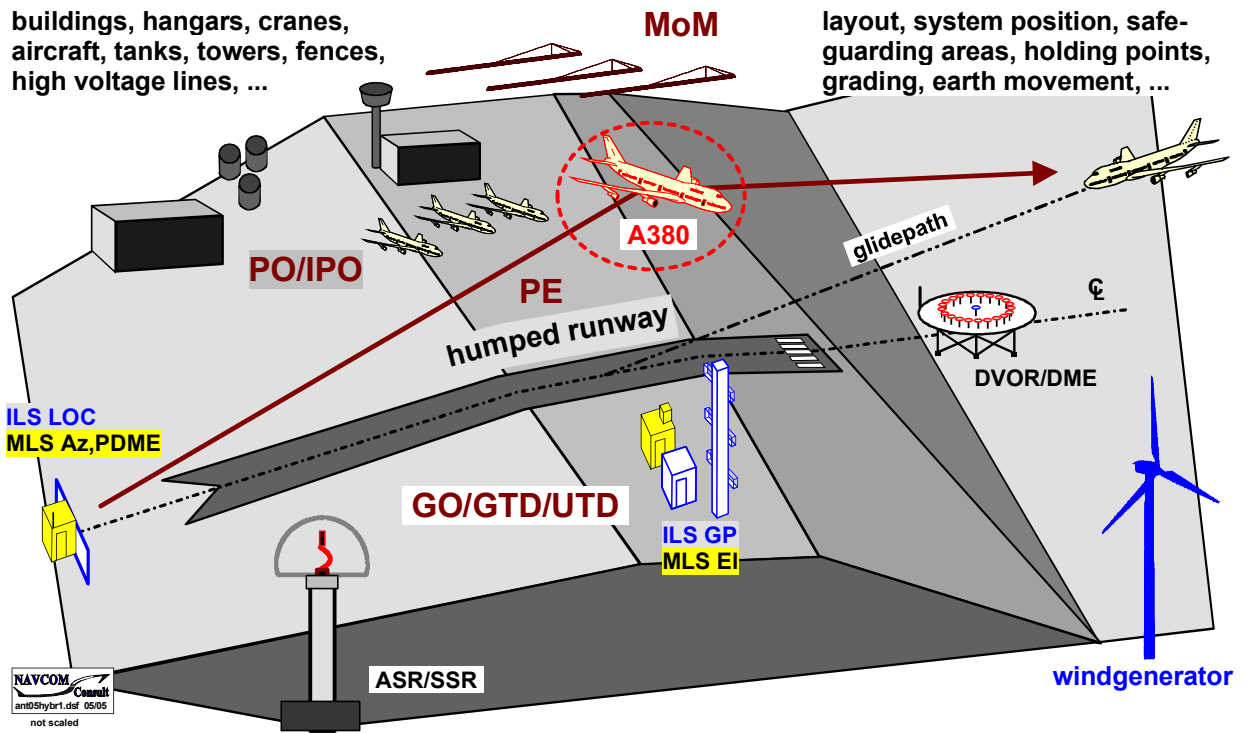

Fig. 1: General principal sketch of an airport with exemplified typical objects and terrain peculiarities; examples of systems and different associated numerical methods ;

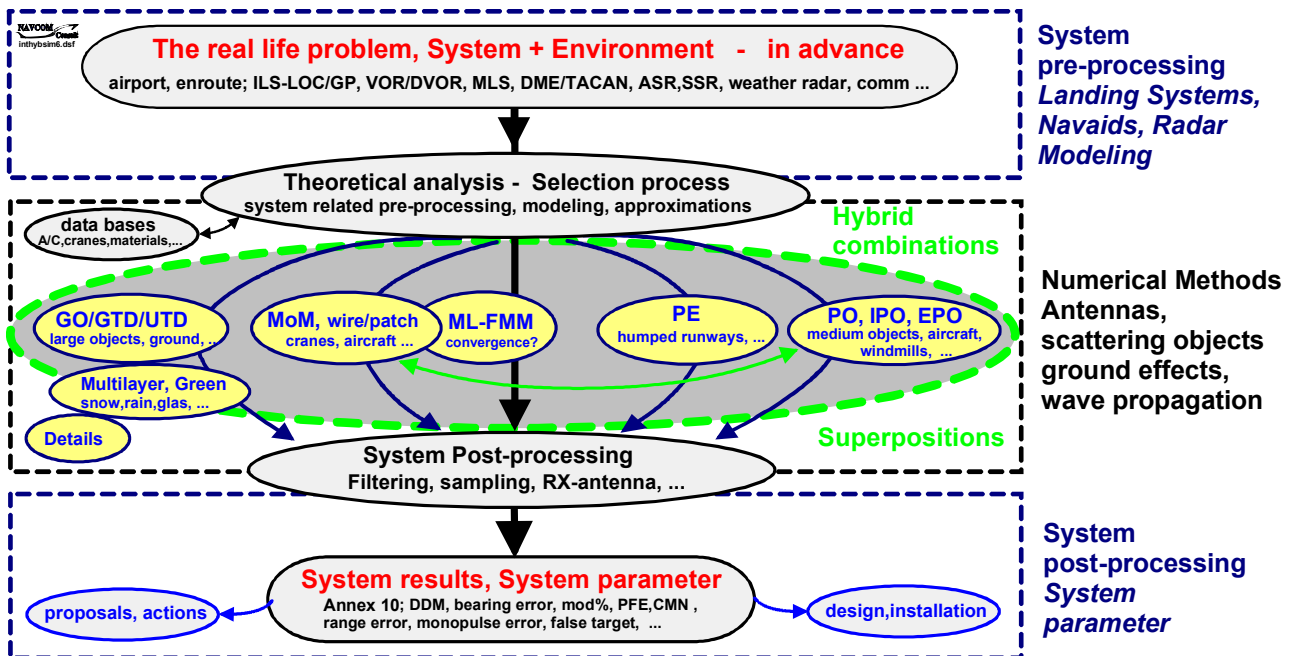

Fig. 2: Flow chart of the IHSS (Integrated Hybrid System Simulations)

Basic Dimensions:
length = 78.9m span = 79.8m height = 24.1m
37054 triangular patches (110MHz)

Analysis by the IPO-method
improved and extended PO :
(modified) basic PO-currents
+ rim currents
+ Fock currents
+ shadowing effects

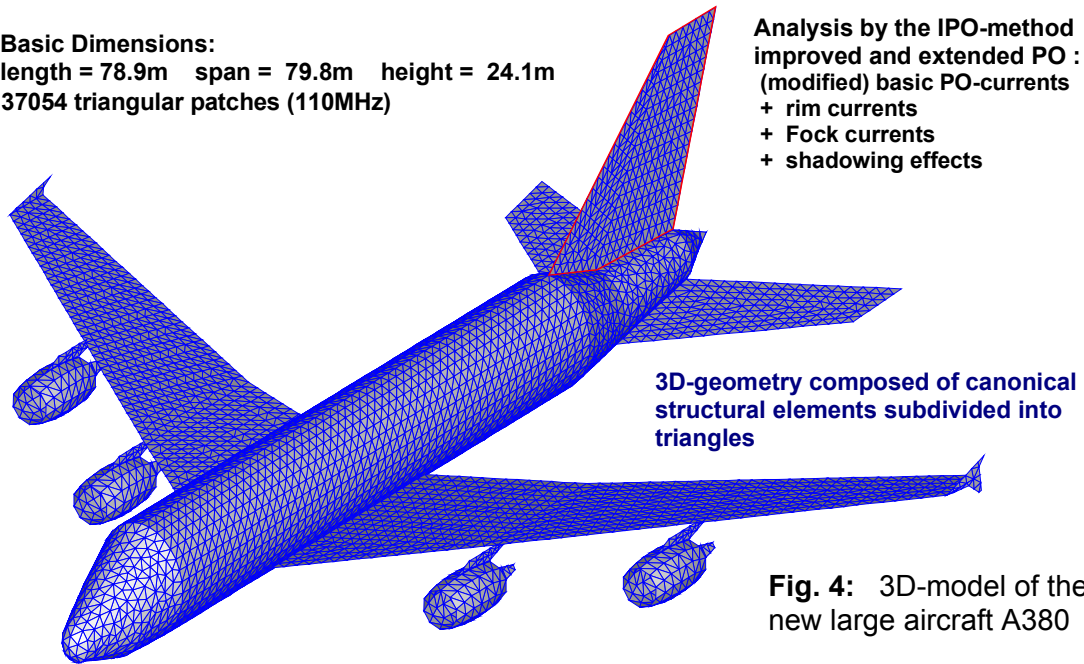

Fig. 4: 3D-model of the new large aircraft A380

NAVCOM
Consult
a380casa3.dsf 01/06

A380 aircraft in various positions and orientations on the airport

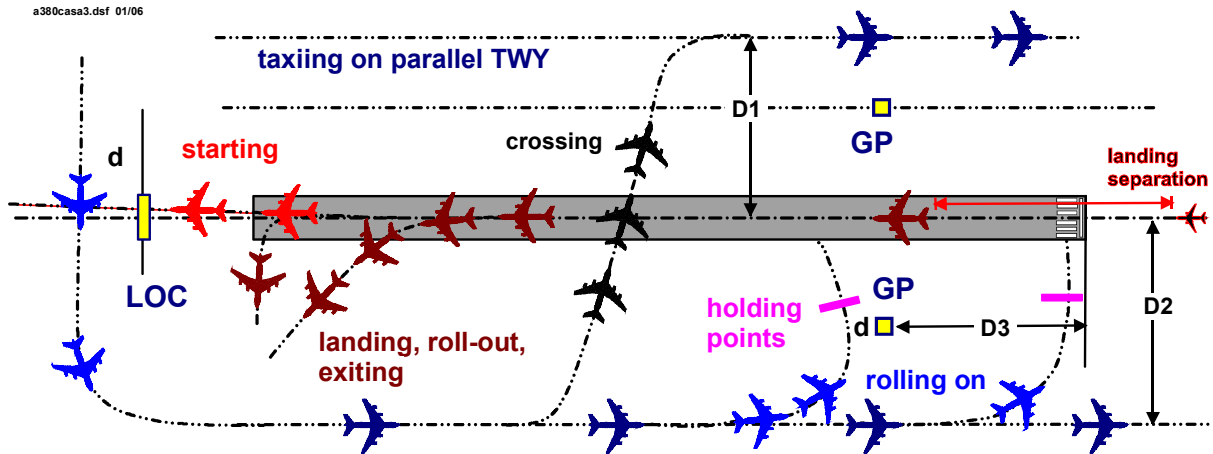

Fig. 5: Set of scenarios for positions and orientations of A380

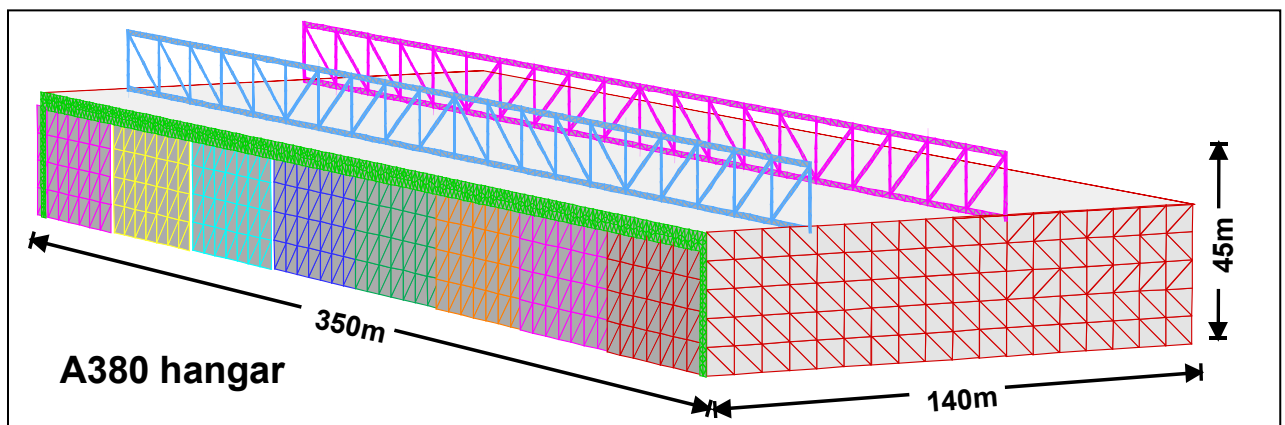

Fig. 6: 3D-model of a 380-hangar; example of an extremely large buildings on airports

**Tower crane
LIEBHERR 550EC-H**

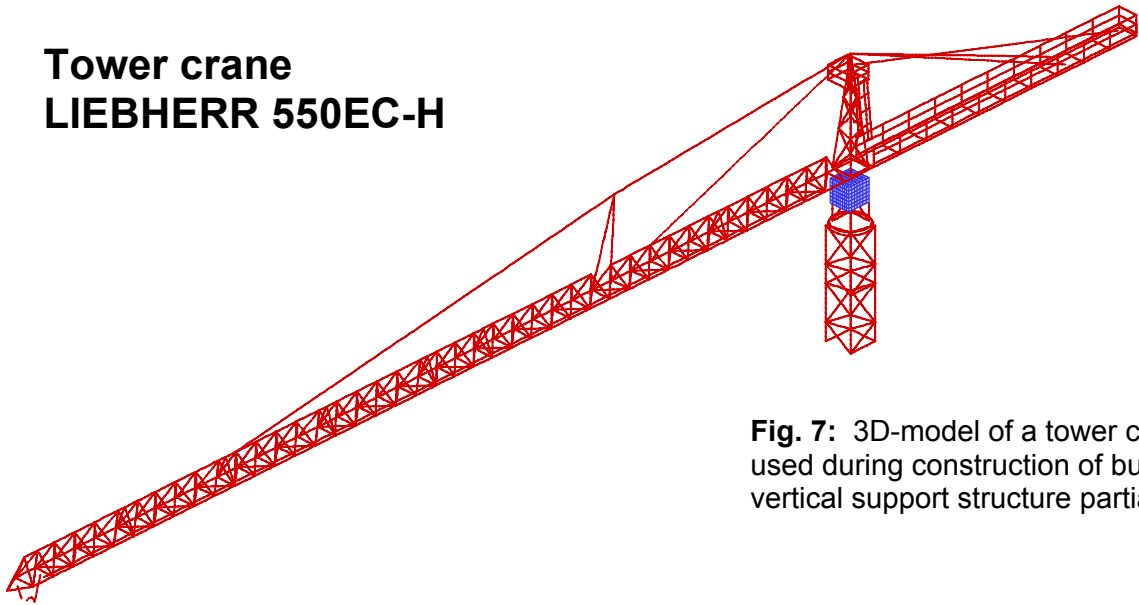

Fig. 7: 3D-model of a tower crane; used during construction of buildings; vertical support structure partially

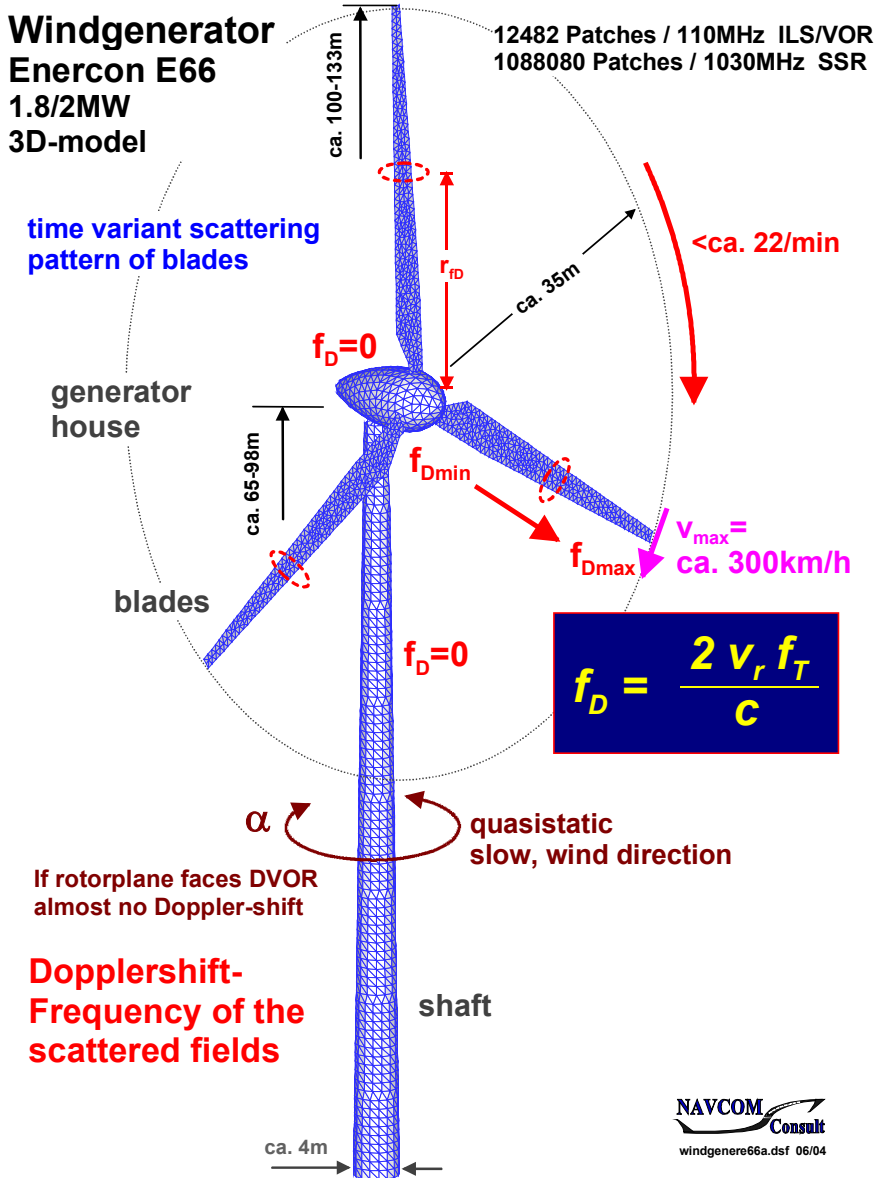

Fig. 8: 3D-model of a medium large specific windgenerator; exposed to nav aids and radar systems. The size is steadily increasing.

DDM distortions on glidepath with moving A380 from centerline to fast roll-off taxiway

abroil2_a.xls

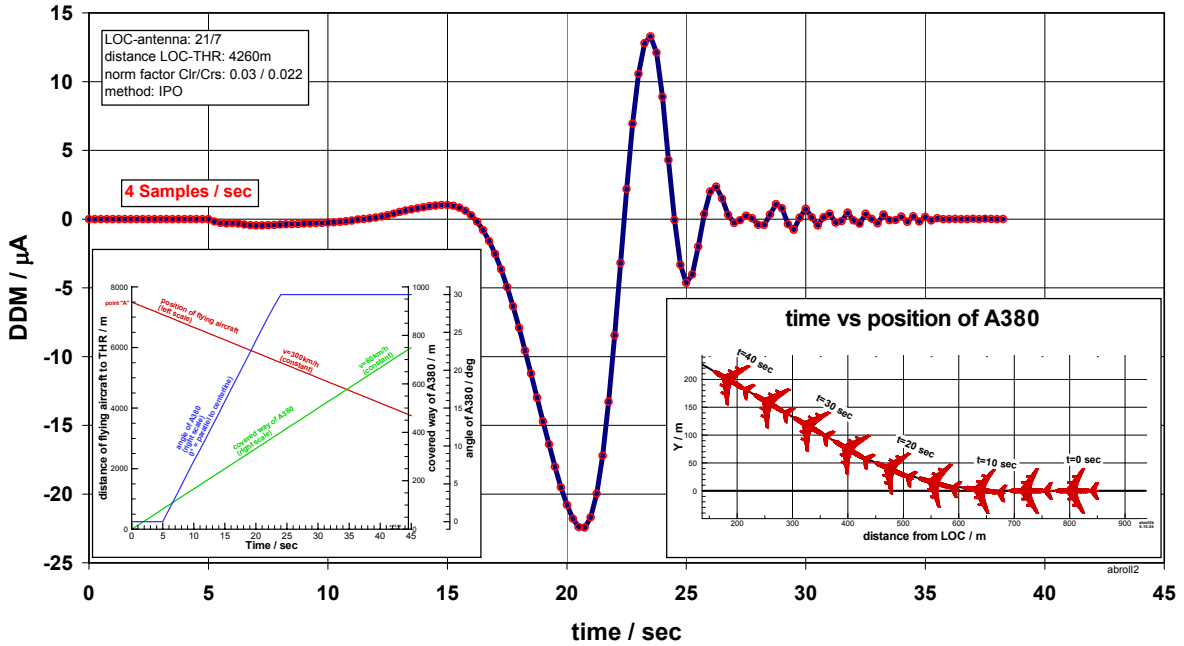

Fig. 9: ILS; DDM-distortions on the glidepath for an A380 rolling off in a distance of 700m from a wide aperture dual frequency localizer. Landing aircraft is passing Point A at 0sec.

HONG KONG MSSR Beacon Hill (BH) - Kowloon Peak (KP) SFN Station Scattered Electric Field (3000ft above ground) from SFN Tower and Building (complete worst case model)

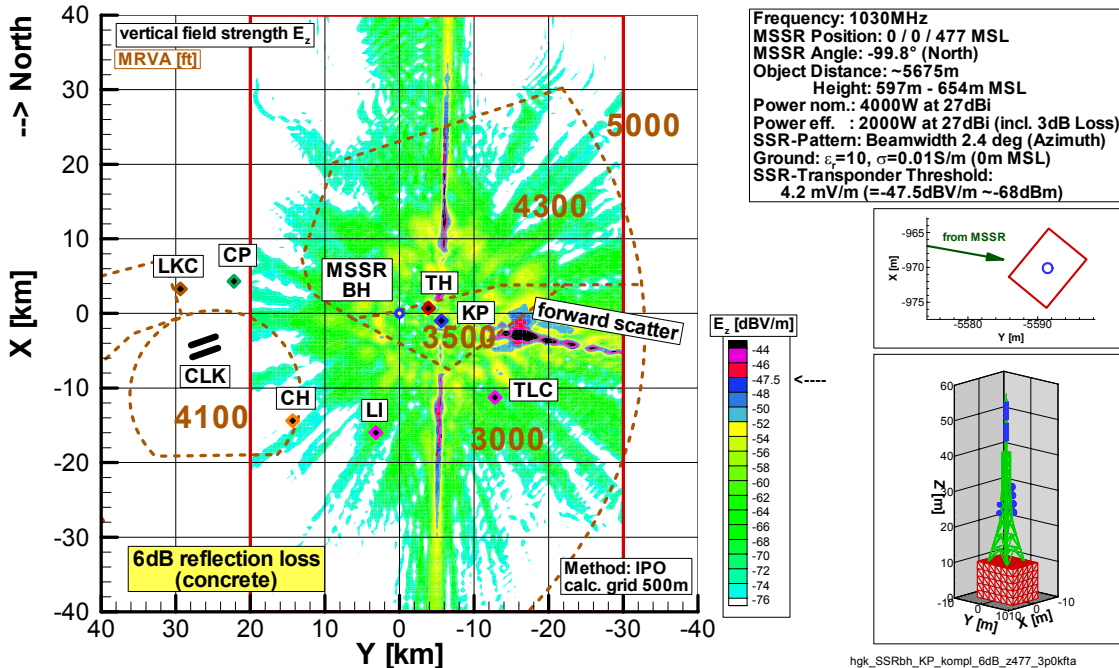

Fig. 10: MSSR; Interrogation field caused by reflections and scattering at the TV-station (Fig. 3 detailed model) on a horizontal plane of 80kmx80km in the overall minimum height of 3000ft of the MRVA